



## DRIVELINE COMPONENTS CATALOG YOKE SHAFTS



**J300P-8  
SEPTEMBER 2008**

**Supersedes  
J300-P8 Dated  
April 2004**



**SPICER**<sup>®</sup>  
*Drivetrain Products*

# HOW TO USE THIS CATALOG

## To identify a yoke shaft:

1. Determine the Series
2. Determine the spline outside diameter and number of teeth.
3. Determine the length from centerline of joint to end of spline.

Use of the above data will narrow the selection down to a specific yoke shaft with exact dimensions or a selection of yoke shafts having common dimensions.

Within those common shafts, there may be part numbers that have different lengths of spline, different distances from the end of the spline to the radius at the neck of the shaft or different maximum working angles.

Footnotes for parts and assemblies that are discontinued, will be discontinued upon depletion of stock, or not sold separately, are indicated by a symbol next to the part number. Match the symbol to the appropriate status at the bottom of the page. All other footnotes are located immediately below the yoke dimensional data.

Series and all pertinent series dimensions appear as shown in the samples below:

### Spicer Life Series®:

	K Centerline to End of Spline	L Centerline to End of Can/Tube	Style	Boot Can/ Tube Assembly Part Number	Plug Part Number	Yoke Shaft Part Number
①	<b>SPL140 SERIES E-5.028 D-1.936</b>					<b>USE KIT SPL140X</b>
②	3.0710-30 Involute Spline					
	11.8110	8.6610	1	91-30-2-132M	140-68-13	140-82-21X
③	<b>SPL170 SERIES E-6.024 D-2.166</b>					<b>USE KIT SPL170X</b>
	3.4640-34 Involute Spline					
	11.0620	7.5000	1	100-30-2-84M	6-68-64	170-82-191X

### All Others:

	K Centerline to End of Spline	R End of Spline to Point of Radius	L Spline Length	Yoke Shaft Part Number	Notes
①	<b>1550 SERIES E-5.250 D-1.375</b>				<b>USE KIT NO. 5-155X, 5-808X</b>
②	1.750-16 Spline				
	4.750	2.500	1.438	4-82-341•	
	6.375	4.156	2.500	4-82-601-1•	High angle yoke
	6.375	4.156	2.500	4-82-601-2•	High angle yoke
③	6.812	4.250	2.500	4-82-371	High angle yoke
	7.940	5.375	3.000	4-82-411-7	High angle yoke

**IMPORTANT NOTICE:** The data listed herein is correct to the best of our knowledge and belief; having been compiled from reliable and official sources of information. However, WE CANNOT ASSUME ANY RESPONSIBILITY for possible error.



# YOKE SHAFTS

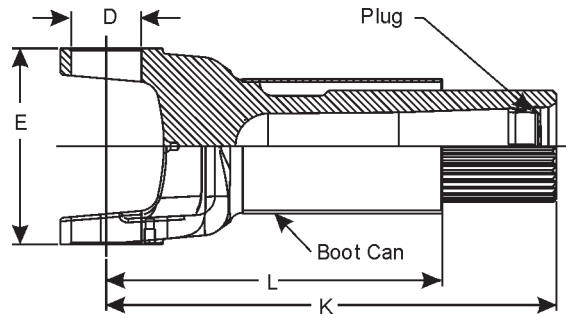

K Centerline to End of Spline	L Centerline to End of Can/Tube	Style	Boot Can/ Tube Assembly Part Number	Plug Part Number	Yoke Shaft Part Number
<b>SPL140 SERIES</b>		<b>E-5.028 D-1.936</b>	<b>USE KIT SPL140X</b>		
<b>3.0710-30 Involute Spline</b>					
11.811	8.661	1	91-30-2-132M	140-68-13	140-82-21X
<b>SPL170 SERIES</b>		<b>E-6.024 D-2.166</b>	<b>USE KIT SPL170X</b>		
<b>3.4640-34 Involute Spline</b>					
11.062	7.500	1	100-30-2-84M	170-68-23	170-82-191X
12.441	8.720	1	100-30-2-115M	6-68-64	170-82-121X
12.441	9.350	1	100-30-2-131M	170-68-23	170-82-131X
13.457	9.744	1	100-30-2-141M	170-68-23	170-82-101X
13.850	7.894	1	100-30-2-94M	170-68-23	170-82-71X
15.031	11.516	1	100-30-2-186M	170-68-23	170-82-61X
<b>3.8580-38 Involute Spline</b>					
11.811	7.696	1	109-30-2-94M	170-68-13	170-82-21X
<b>SPL250 SERIES</b>		<b>E-5.984 D-2.362</b>	<b>USE KIT SPL250X</b>		
<b>3.8580-38 Involute Spline</b>					
11.811	8.555	1	109-30-2-132M	250-68-13	250-82-21X

• Part is discontinued    ■ Part is available until supply is exhausted    ▲ Not sold separately



**Important: See Safety Information in General Information Section (J300P-GI)**

# YOKE SHAFTS

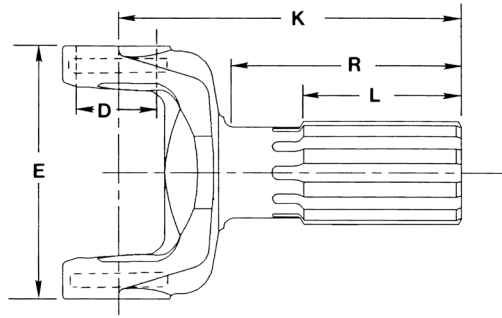

K Centerline to End of Spline	R End of Spline to Point of Radius	L Spline Length	Yoke Shaft Part Number	Notes
<b>1000 SERIES E-2.188 D-.938</b>				<b>USE KIT NO. 5-170X</b>
<b>1.250-16 Spline</b>				
5.562	3.688	1.625	10-82-21	
<b>1100 SERIES E-2.656 D-.938</b>				<b>USE KIT NO. 5-101X OR 5-111X</b>
<b>1.060-16 Spline</b>				
3.656	2.875	1.688	1-82-21	
<b>1210 SERIES E-2.688 D-1.062</b>				<b>USE KIT NO. 5-443X</b>
<b>1.062-16 Spline</b>				
3.969	2.594	1.750	2-82-1651•	
<b>1.250-15 Based On 16 Spline</b>				
6.250	4.125	2.000	2-82-1641•	
6.250	4.125	3.250	2-82-1781•	Spline not glidecoated
8.391	7.866	2.250	2-82-1731	
<b>1310 SERIES E-3.469 D-1.062</b>				<b>USE KIT NO. 5-153X, 5-200X, 5-785X, 5-810X</b>
<b>1.156-27 Involute Spline</b>				
8.547	6.422	1.562	2-82-1371•	
<b>1.250-16 Spline</b>				
4.594	2.938	1.656	2-82-211	
5.125	3.562	1.875	2-82-51	
5.812	4.156	2.000	2-82-41	
6.875	4.812	2.000	2-82-431X•	Spline not glidecoated
<b>1.302-30 Involute Spline</b>				
5.625	3.875	2.500	2-82-871	
<b>1.375-16 Spline</b>				
4.562	3.219	1.922	2-82-11	
4.625	3.406	2.063	2-82-641	
5.312	3.844	2.250	2-82-21	
7.062	5.190	2.500	2-82-58X	Spline not glidecoated
9.375	6.938	2.250	2-82-201X	Spline not glidecoated
<b>1.500-16 Spline</b>				
3.656	2.406	1.440	2-82-861	
<b>3.000-23 Involute Spline</b>				
7.420	4.720	3.310	2-82-1891	Material: aluminum
7.420	4.720	3.310	2-82-1941X•	Material: aluminum; Uses plug number 5-68-164
<b>1330 SERIES E-3.625 D-1.062</b>				<b>USE KIT NO. 5-213X, 5-790X, 5-791X</b>
<b>3.000-23 Involute Spline</b>				
8.250	5.550	4.140	2-82-1961	Material: aluminum

• Part is discontinued    ■ Part is available until supply is exhausted    ▲ Not sold separately



## YOKE SHAFTS

K	R	L	Yoke Shaft Part Number	Notes
Centerline to End of Spline	End of Spline to Point of Radius	Spline Length		
<b>1350 SERIES E-3.875 D-1.188</b>			<b>USE KIT NO. 5-178X, 5-799X</b>	
<b>1.175-27 Spline</b>				
6.062	2.031	1.844	3-82-1201•	Wheel yoke shaft, BS Style
<b>1.175-27 Involute Spline</b>				
5.531	3.062	1.750	3-82-1161	Wheel yoke shaft, BS Style
<b>1.177-27 Involute Spline</b>				
6.740	3.481	1.844	3-82-1141-1•	GM differential yoke shaft, BS style
7.290	4.031	1.844	3-82-1141-2•	GM differential yoke shaft, BS style
<b>1.252-31 Involute Spline</b>				
4.547	1.719	1.440	3-82-1381•	GM differential yoke shaft, BS style
4.547	1.719	1.440	3-82-1431•	
<b>1.302-30 Involute Spline</b>				
6.590	5.430	2.219	3-82-1151-2	Wheel yoke shaft, BS Style
7.360	5.750	2.219	3-82-1151-1■	Wheel yoke shaft, BS Style
7.422	4.340	2.000	3-82-961-2•	BS style
<b>1.500-10 Spline</b>				
5.820	—	1.500	3-82-981	Has .375"-16 threaded hole at spline end
<b>1.500-16 Spline</b>				
4.188	2.531	1.375	3-82-971	
4.812	2.781	1.750	3-82-71	Spline not glidecoated
5.188	3.063	2.000	3-82-61	Spline not glidecoated
5.844	3.781	2.000	3-82-1321	
6.406	4.344	2.000	3-82-341	
6.531	4.406	2.500	3-82-161	
6.812	4.688	2.500	3-82-181	Spline not glidecoated
7.250	5.125	2.500	3-82-211	
7.750	5.125	2.500	3-82-761X	Spline not glidecoated
<b>1410 SERIES E-4.438 D-1.188</b>			<b>USE KIT NO. 5-160X, 5-801X</b>	
<b>1.358-21 Involute Spline</b>				
5.547	2.700	2.000	3-82-1291•	
<b>1.500-16 Spline</b>				
4.969	3.250	2.000	3-82-1191	
5.406	3.312	2.000	3-82-1301	
6.312	4.470	2.500	3-82-201	Spline not glidecoated
7.844	5.250	3.000	3-82-168X•	Spline not glidecoated
<b>1.500-16 Spline</b>				
8.406	5.750	3.000	3-82-58X	Spline not glidecoated
8.969	6.281	3.000	3-82-268X	Spline not glidecoated
<b>1.750-16 Spline</b>				
4.547	2.672	1.438	3-82-261	
5.406	3.531	1.438	3-82-811	
6.340	4.410	3.000	3-82-781	Spline not glidecoated
<b>1480 SERIES E-4.438 D-1.375</b>			<b>USE KIT NO. 5-188X, 5-803X</b>	
<b>1.562-16 Spline</b>				
6.750	4.500	2.750	3-82-1121	
<b>2.250-10 Spline</b>				
4.380	2.812	1.594	3-82-271	
<b>2.994-24 Involute Spline</b>				
8.960	6.149	4.566	5005288	Material: aluminum

• Part is discontinued    ■ Part is available until supply is exhausted    ▲ Not sold separately



**Important: See Safety Information in General Information Section (J300P-GI)**

# YOKE SHAFTS

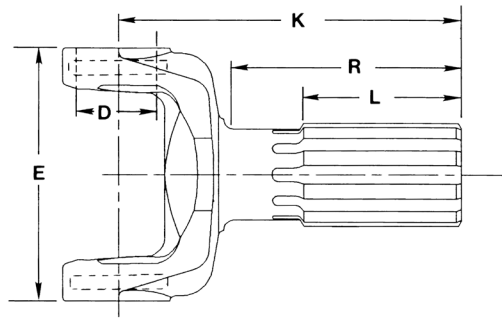

K	R	L	Yoke Shaft Part Number	Notes
Centerline to End of Spline	End of Spline to Point of Radius	Spline Length		
<b>1550 SERIES E-5.250 D-1.375</b>			<b>USE KIT NO. 5-155X, 5-808X</b>	
<b>1.750-16 Spline</b>				
4.750	2.500	1.438	4-82-341•	
6.375	4.156	2.500	4-82-601-1•	High angle yoke
6.812	4.250	2.500	4-82-371	High angle yoke
7.560	4.156	2.500	4-82-601-2•	High angle yoke
7.940	5.375	3.000	4-82-411-7	High angle yoke
8.438	5.875	3.000	4-82-411-1	High angle yoke
8.625	5.812	3.000	4-82-401	High angle yoke
9.750	4.531	2.875	4-82-361-2•	High angle yoke
9.750	7.094	3.000	4-82-561	
<b>2.000-16 Spline</b>				
5.844	3.594	2.250	4-82-511•	
6.120	4.484	3.000	4-82-211	
<b>2.500-16 Spline</b>				
4.562	2.750	1.562	4-82-191	
4.812	2.938	1.562	4-82-201	
5.172	3.328	1.562	4-82-621-1•	
5.609	3.672	1.562	4-82-621-3	
6.188	4.250	1.562	4-82-621-4	
6.672	4.734	1.562	4-82-621-2	

• Part is discontinued    ■ Part is available until supply is exhausted    ▲ Not sold separately



# YOKE SHAFTS

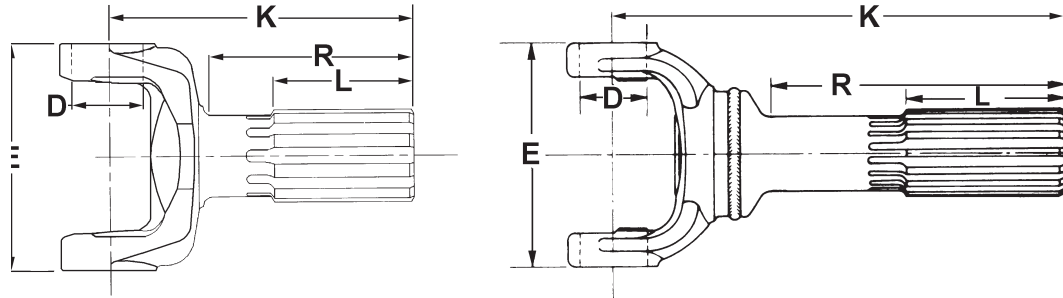

K	R	L	Yoke Shaft Part Number	Notes
Centerline to End of Spline	End of Spline to Point of Radius	Spline Length		
<b>1610 SERIES E-5.312 D-1.875 USE KIT NO. 5-279X, 5-674X</b>				
<b>2.000-16 Spline</b>				
7.297	4.547	3.000	5-82-871	
7.875	6.438	2.750	5-82-921	
7.875	5.312	3.000	5-82-211	
9.531	5.969	3.000	5-82-791-2	
9.812	6.250	3.000	5-82-791-4•	
10.063	6.500	3.000	5-82-791-3	
10.438	6.875	3.500	5-82-831-4	
10.812	7.562	3.500	5-82-781	
12.063	8.500	3.500	5-82-831-1	
13.063	9.063	3.500	5-82-961-3	High angle yoke
14.063	10.063	3.500	5-82-961-5	High angle yoke
14.406	10.406	3.500	5-82-961-7	High angle yoke
14.562	10.562	3.500	5-82-961-6	High angle yoke
15.000	11.000	3.500	5-82-961-1	High angle yoke
15.500	11.500	3.500	5-82-961-2	High angle yoke
<b>2.500-16 Spline</b>				
12.969	9.094	4.000	5-82-1011M	Metric Yokeshaft
<b>2.672-17 Based On 18 Spline</b>				
4.219	2.531	1.594	5-82-191•	
<b>2.672-18 Involute Spline</b>				
6.063	4.003	1.500	5-82-951	Spline not glidecoated
6.850	4.790	1.500	5-82-951-2	Spline not glidecoated
7.140	5.080	1.500	5-82-951-1	Spline not glidecoated
<b>2.674-18 Involute Spline</b>				
4.125	2.500	1.500	5-82-161	
<b>1710 SERIES E-6.094 (6.190 FOR HR STYLE) D-1.938 USE KIT NO. 5-280X, 5-675X</b>				
<b>2.500-15 Based On 16 Spline</b>				
9.656	6.656	3.500	6-82-1331-1•	
<b>2.500-16 Spline</b>				
8.156	5.406	3.000	6-82-1251	
8.531	5.781	3.500	6-82-1131-2	
8.650	5.906	3.000	6-82-1391	
8.910	5.570	2.750	6-82-1371	
9.031	6.281	3.375	6-82-1291	
9.063	6.312	3.500	6-82-1131-4•	
9.656	6.312	3.500	6-82-1171-10	
9.820	6.480	3.160	6-82-1411•	
10.031	6.688	3.500	6-82-1171-1	
10.156	6.812	3.500	6-82-1171-11	

• Part is discontinued    ■ Part is available until supply is exhausted    ▲ Not sold separately



**Important: See Safety Information in General Information Section (J300P-GI)**

# YOKE SHAFTS

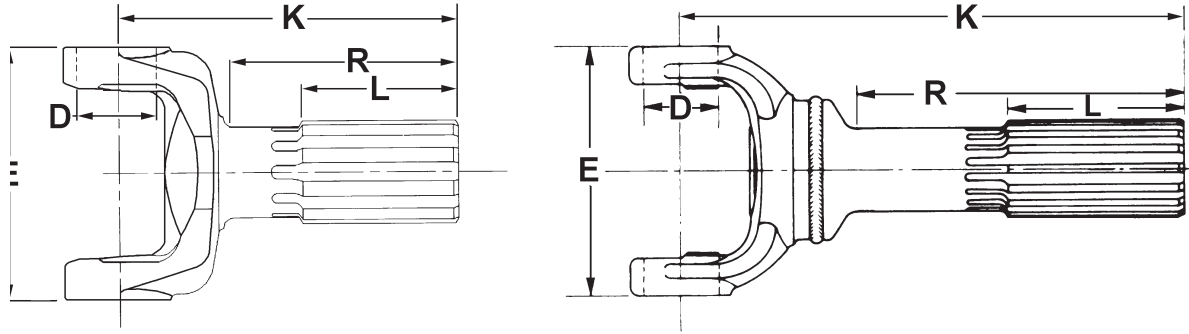

K Centerline to End of Spline	R End of Spline to Point of Radius	L Spline Length	Yoke Shaft Part Number	Notes
<b>1710 SERIES (Continued) E-6.094 (6.190 FOR HR STYLE) D-1.938 USE KIT NO. 5-280X, 5-675X</b>				
<b>2.500-16 Spline (Continued)</b>				

10.320	6.980	3.160	6-82-1381	
10.656	7.312	3.500	6-82-1171-12	
10.656	6.906	3.500	6-82-1281-6	High angle yoke
10.660	8.656	3.500	6-82-1351-5	High angle yoke
11.000	8.000	4.000	6-82-1231	
11.031	7.688	3.500	6-82-1171-7•	High angle yoke
11.156	7.812	3.500	6-82-1171-2	
11.531	8.094	4.000	6-82-1141	
11.656	8.312	3.500	6-82-1171-13	
11.660	8.656	3.500	6-82-1351-7•	
11.781	8.094	4.000	6-82-1091-12	
12.000	8.312	4.000	6-82-1091-16•	
12.094	8.344	3.500	6-82-1281•	High angle yoke
12.094	7.969	3.500	6-82-1351-2	High angle yoke
12.156	8.469	4.000	6-82-1091-1	
12.281	8.594	4.000	6-82-1091-13	
12.438	9.094	3.500	6-82-1171-6	
12.594	8.844	3.500	6-82-1281-3	High angle yoke
12.688	8.562	4.000	6-82-1341-1	High angle yoke
12.781	8.656	3.500	6-82-1351-3	High angle yoke
13.000	9.656	3.500	6-82-1171-5•	
13.094	9.344	3.500	6-82-1281-1	High angle yoke
13.094	8.969	3.500	6-82-1351-4	High angle yoke
13.156	9.460	4.000	6-82-1341-13	High angle yoke
13.375	9.625	4.000	6-82-1061-15	High angle yoke
13.375	9.250	4.000	6-82-1341-2	High angle yoke
13.625	9.938	4.000	6-82-1091-9	High angle yoke
13.750	9.625	4.000	6-82-1341-3	High angle yoke
14.000	9.875	4.000	6-82-1341-4	High angle yoke
14.156	10.469	4.000	6-82-1091-3	High angle yoke
14.281	10.156	4.000	6-82-1341-5	High angle yoke
14.750	10.625	4.000	6-82-1341-6	High angle yoke
15.031	10.906	4.000	6-82-1341-7	High angle yoke
15.375	11.250	4.000	6-82-1341-8	High angle yoke
15.750	11.625	4.000	6-82-1341-9	High angle yoke
16.031	11.906	4.000	6-82-1341-10	High angle yoke
16.406	12.281	4.000	6-82-1341-11	High angle yoke
16.688	9.562	4.000	6-60-275-0214•	High angle yoke

• Part is discontinued    ■ Part is available until supply is exhausted    ▲ Not sold separately





# YOKE SHAFTS



K	R	L	Yoke Shaft Part Number	Notes
Centerline to End of Spline	End of Spline to Point of Radius	Spline Length		
<b>1710 SERIES (Continued) E-6.094 (6.190 FOR HR STYLE) D-1.938 USE KIT NO. 5-280X, 5-675X</b>				
<b>2.500-16 Spline (Continued)</b>				
16.750	12.625	4.000	6-82-1341-12	High angle yoke
16.875	9.562	4.000	6-60-275-0220•	High angle yoke
17.031	13.281	4.000	6-60-275-0225•	High angle yoke
17.500	13.750	4.000	6-60-275-0308•	High angle yoke
<b>3.248-18 Involute Spline</b>				
5.250	3.016	2.000	6-82-341	
6.125	3.875	2.000	6-82-691	
7.250	4.938	2.000	6-82-411	
7.875	5.563	2.000	6-82-1001	
<b>1760 SERIES E-7.000 (7.094 FOR HR STYLE) D-1.938 USE KIT NO. 5-407X, 5-677X</b>				
<b>2.500-16 Spline</b>				
11.000	8.188	4.000	6.3-82-21-1	
11.500	8.688	4.000	6.3-82-21-2•	
12.000	9.188	4.000	6.3-82-21-3	
12.375	9.562	4.000	6.3-82-21-5•	
12.500	9.688	4.000	6.3-82-21-4■	
12.875	10.062	4.000	6.3-82-21-6■	
13.375	10.562	4.000	6.3-82-21-7•	
13.875	11.062	4.000	6.3-82-21-8•	
14.375	11.562	4.000	6.3-82-21-9•	
14.875	12.062	4.000	6.3-82-21-10•	
15.375	12.562	4.000	6.3-82-21-11	
<b>1810 SERIES E-7.547 (7.643 FOR HR STYLE) D-1.938 USE KIT NO. 5-281X, 5-676X</b>				
<b>3.000-16 Spline</b>				
10.438	6.562	4.000	6.5-82-451-12	High angle yoke
11.438	7.812	4.000	6.5-82-451-1	High angle yoke
11.938	8.312	4.000	6.5-82-451-3•	High angle yoke
12.188	8.562	4.500	6.5-82-461-1	High angle yoke
12.438	8.813	4.000	6.5-82-451-5	High angle yoke
12.688	9.062	4.500	6.5-82-461-2	High angle yoke
13.188	9.562	4.500	6.5-82-461-3	High angle yoke
13.688	10.062	4.500	6.5-82-461-4•	High angle yoke
13.812	10.188	4.500	6.5-82-461-8	High angle yoke
14.438	10.812	4.500	6.5-82-461-9	High angle yoke
15.062	11.438	4.500	6.5-82-461-10	High angle yoke
15.688	12.062	4.500	6.5-82-461-11	High angle yoke
16.312	12.688	4.500	6.5-82-461-12	High angle yoke
<b>3.248-18 Involute Spline</b>				
6.719	4.312	2.750	6.5-82-511-1	
7.219	4.812	2.750	6.5-82-511-3	
<b>1880 SERIES E-8.094 D-2.188 USE KIT NO. 5-308X</b>				
<b>3.000-16 Spline</b>				
12.844	8.531	4.500	8-82-161-1	
14.844	10.531	4.500	8-82-161-6•	
17.469	13.156	4.500	8-82-161-12	
<b>4.156-24 Involute Spline</b>				
7.219	4.156	2.625	8-82-171-1	

• Part is discontinued    ■ Part is available until supply is exhausted    ▲ Not sold separately



**Important: See Safety Information in General Information Section (J300P-GI)**

1-82-21 .....4	3-82-761X.....5	6-82-1091-13 .....8	6.3-82-21-9 .....9
10-82-21 .....4	3-82-781 .....5	6-82-1091-16 .....8	6.3-82-21-10 .....9
140-82-21X.....3	3-82-811 .....5	6-82-1131-2 .....7	6.3-82-21-11 .....9
170-82-101X.....3	3-82-961-2 .....5	6-82-1131-4 .....7	6.5-82-451-1 .....9
170-82-121X.....3	3-82-971 .....5	6-82-1141 .....8	6.5-82-451-3 .....9
170-82-131X.....3	3-82-981 .....5	6-82-1171-1 .....7	6.5-82-451-5 .....9
170-82-191X.....3	4-82-191 .....6	6-82-1171-2 .....8	6.5-82-451-12 .....9
170-82-21X.....3	4-82-201 .....6	6-82-1171-5 .....8	6.5-82-461-1 .....9
170-82-61X.....3	4-82-211 .....6	6-82-1171-6 .....8	6.5-82-461-2 .....9
170-82-71X.....3	4-82-341 .....6	6-82-1171-7 .....8	6.5-82-461-3 .....9
2-82-11 .....4	4-82-361-2 .....6	6-82-1171-10 .....7	6.5-82-461-4 .....9
2-82-1371 .....4	4-82-371 .....6	6-82-1171-11 .....7	6.5-82-461-8 .....9
2-82-1641 .....4	4-82-401 .....6	6-82-1171-12 .....8	6.5-82-461-9 .....9
2-82-1651 .....4	4-82-411-1 .....6	6-82-1171-13 .....8	6.5-82-461-10 .....9
2-82-1731 .....4	4-82-411-7 .....6	6-82-1231 .....8	6.5-82-461-11 .....9
2-82-1781 .....4	4-82-511 .....6	6-82-1251 .....7	6.5-82-461-12 .....9
2-82-1891 .....4	4-82-561 .....6	6-82-1281 .....8	6.5-82-511-1 .....9
2-82-1941X .....4	4-82-601-1 .....6	6-82-1281-1 .....8	6.5-82-511-3 .....9
2-82-1961 .....4	4-82-601-2 .....6	6-82-1281-3 .....8	8-82-161-1 .....9
2-82-201X.....4	4-82-621-1 .....6	6-82-1281-6 .....8	8-82-161-6 .....9
2-82-21 .....4	4-82-621-2 .....6	6-82-1291 .....7	8-82-161-12 .....9
2-82-211 .....4	4-82-621-3 .....6	6-82-1331-1 .....7	8-82-171-1 .....9
2-82-41 .....4	4-82-621-4 .....6	6-82-1341-1 .....8	
2-82-431X .....4	5-82-1011M .....7	6-82-1341-2 .....8	
2-82-51 .....4	5-82-161 .....7	6-82-1341-3 .....8	
2-82-58X .....4	5-82-191 .....7	6-82-1341-4 .....8	
2-82-641 .....4	5-82-211 .....7	6-82-1341-5 .....8	
2-82-861 .....4	5-82-781 .....7	6-82-1341-6 .....8	
2-82-871 .....4	5-82-791-2 .....7	6-82-1341-7 .....8	
250-82-21X.....3	5-82-791-3 .....7	6-82-1341-8 .....8	
3-82-1121 .....5	5-82-791-4 .....7	6-82-1341-9 .....8	
3-82-1141-1 .....5	5-82-831-1 .....7	6-82-1341-10 .....8	
3-82-1141-2 .....5	5-82-831-4 .....7	6-82-1341-11 .....8	
3-82-1151-1 .....5	5-82-871 .....7	6-82-1341-12 .....9	
3-82-1151-2 .....5	5-82-921 .....7	6-82-1341-13 .....8	
3-82-1161 .....5	5-82-951-1 .....7	6-82-1351-2 .....8	
3-82-1191 .....5	5-82-951-2 .....7	6-82-1351-3 .....8	
3-82-1201 .....5	5-82-951 .....7	6-82-1351-4 .....8	
3-82-1291 .....5	5-82-961-1 .....7	6-82-1351-5 .....8	
3-82-1301 .....5	5-82-961-2 .....7	6-82-1351-7 .....8	
3-82-1321 .....5	5-82-961-3 .....7	6-82-1371 .....7	
3-82-1381 .....5	5-82-961-5 .....7	6-82-1381 .....8	
3-82-1431 .....5	5-82-961-6 .....7	6-82-1391 .....7	
3-82-161 .....5	5-82-961-7 .....7	6-82-1411 .....7	
3-82-168X .....5	5005288 .....5	6-82-341 .....9	
3-82-181 .....5	6-60-275-0214 .....8	6-82-411 .....9	
3-82-201 .....5	6-60-275-0220 .....9	6-82-691 .....9	
3-82-211 .....5	6-60-275-0225 .....9	6.3-82-21-1 .....9	
3-82-261 .....5	6-60-275-0308 .....9	6.3-82-21-2 .....9	
3-82-268X.....5	6-82-1001 .....9	6.3-82-21-3 .....9	
3-82-271 .....5	6-82-1091-1 .....8	6.3-82-21-4 .....9	
3-82-341 .....5	6-82-1091-3 .....8	6.3-82-21-5 .....9	
3-82-58X .....5	6-82-1091-9 .....8	6.3-82-21-6 .....9	
3-82-61 .....5	6-82-1061-15 .....8	6.3-82-21-7 .....9	
3-82-71 .....5	6-82-1091-12 .....8	6.3-82-21-8 .....9	







**SPICER<sup>®</sup>**

*Drivetrain Products*

**Dana Holding Corporation  
Spicer Service Parts**  
PO Box 321  
Toledo, Ohio 43697-0321  
1-800-SAY-DANA (729-3262)

[www.spicerparts.com](http://www.spicerparts.com)

**Dana Holding Corporation  
Spicer Service Parts - Canada**  
5095 South Service Road  
Beamsville, Ontario LOR 1B0

**Dana Holding Corporation  
Spicer Service Parts - International**  
(419) 861-6325

**J300P-8**  
9/08  
Printed in U.S.A

© Dana Limited 2008.  
All rights reserved.