

TM4[®] SUMO[™] HP

Motor/Generator and Inverter System

Product Benefits

- High power permanent magnet motor/generator and inverter combinations
- Seamless integration into Dana's products
- Control algorithms optimized for parallel hybrid or generation applications.

Product Features

- Peak power: Up to 220 kW
- Peak torque: Up to 915 Nm
- Max operating speed: 2,800 RPM

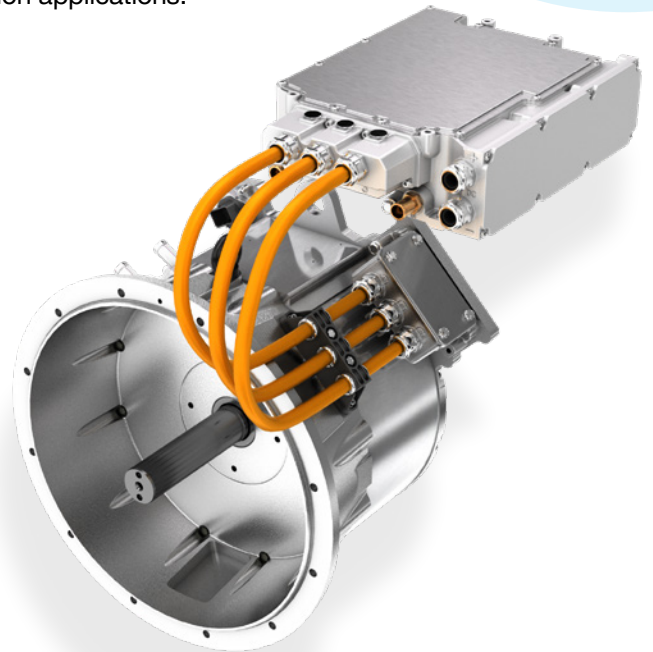

◦ Ideal for High-Power Applications.

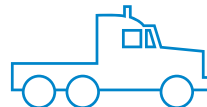
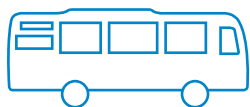

TM4® SUMO™ HP

The TM4 SUMO HP consists of electric powertrains dedicated to high-power applications. The first motor/generator and inverter combination of this line, the TM4 SUMO HP HV900, was purposely developed for series and parallel-hybrid configurations; it can be coupled to diesel engines, multi-speed gearboxes or integrated to axles for ultra-low floor buses.

Motor Features

- Proven permanent magnet technology for optimal efficiency
- Outer rotor topology for maximum torque density
- Low electro-magnetic audible noise
- Low-cogging and ripple torque for better NVH
- Four-quadrant operation
- Double-ended shaft option
- Thermal protection

Standards

- System protection: IP67/IP 6K9K
- Automotive components: AEC-Q100/AEC-Q101/AEC-Q200
- Electromagnetic compatibility EMC: Main automotive intl standards
- Shock and vibration standards: GMW3172 Sprung masses
- Max coolant inlet temperature: 65°C
- Coolant type: 40/60 water-glycol
- Toxic materials and flammability: ROHS, ELV, UL94-V0
- External corrosion resistance: Salt mist, chemical products

Inverter Features

- 3-phase high voltage inverter
- Variable switching frequency
- Reflex™ gate driver technology for high power and current densities
- EMI Filter
- Best-in-class power density
- High efficiency

SYSTEM	Phases	Peak power (kW)	Continuous power (kW)	Peak torque (Nm)	Continuous torque (Nm)	Max operating speed (RPM)
SUMO HP HV900-3P	3	220	160	915	624	2800

600 Vdc, 30 seconds, 45°C
Specifications are subject to change

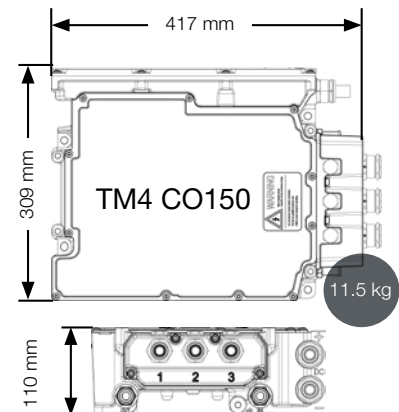
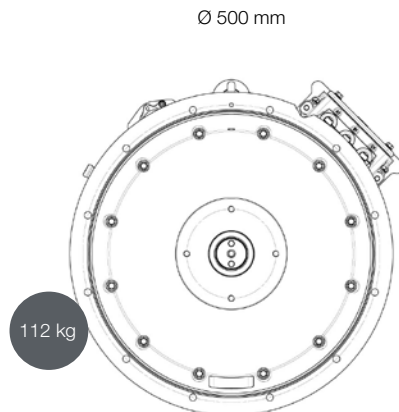
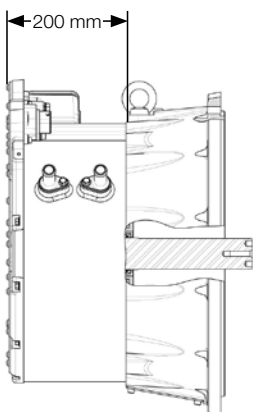

TM4
135 J.-A. Bombardier - Suite 25
Boucherville, Québec
Canada
J4B 8P1
+1 450.645.1444

Visit TM4.com to learn more.

tm4

